

PAGE:	1 of 11
ISSUE:	A 00
DATE:	07/28/15

DOCUMENT TITLE**9.0 LITRE STORED PRESSURE
FOAM FIRE EXTINGUISHER****MODELS: R9AF**

0	07/28/15	ISSUE A FIRST RELEASE NEW DOCUMENT	WJJ	LRL	LHG
REV	DATE	REVISION DESCRIPTION	BY	CHK	APP

COVER PAGE/REVISION STATUS

CONTENTS

- 1. PURPOSE
- 2. GENERAL DESCRIPTION AND OPERATION
- 3. SPECIFICATIONS
- 4. MATERIALS AND CONSTRUCTION
- 5. EXTINGUISHANT
- 6. FINISH
- 7. QUALITY ASSURANCE
- 8. APPROVALS AND RATINGS
- 9. INSTALLATION
- 10. SERVICING AND DRAWINGS

1. PURPOSE

These 9.0 litre foam fire extinguishers are designed to be used on Class A fires, and Class B fires.

Class A fires are defined as fires involving combustible materials such as wood, paper, cloth etc.

Class B fires are defined as fires involving flammable and combustible liquids, petrol, oil and grease etc.

These extinguishers should not be used on Class D fires - fires involving combustible metals, Class F fires - fires involving cooking oils and fats or on Class E fires – fires involving energised electrical equipment.

2. GENERAL DESCRIPTION AND OPERATION

These extinguishers have a stainless steel body fitted with a brass bodied valve assembly. They contain 9.0 litres of foam pressurised with dry nitrogen and a small amount of helium to 1030kPa.

Operation: The valve is a squeeze grip type which, when operated, allows the wet chemical to flow through the valve and hose to the nozzle, where it is discharged as a straight stream at the fire. By employing the squeeze grip “on/off” control principal (intermittent discharge), the operator can move from point to point conserving extinguishant and pressure while fighting the fire.

A ‘pull out type safety pin is used in the valve assembly to prevent accidental discharge of the extinguisher.

The operating procedure for the extinguisher is both written and shown pictorially on the label of the extinguisher. The procedure being:-

- i) Hold upright. Grasp hose and pull to remove safety pin.
- ii) Stand back 3 metres. Aim at base of fire.
- iii) Squeeze handles. Sweep side to side.

As the extinguisher incorporates a siphon tube, it must be used in the upright position. When the operating lever is squeezed, it causes the check to lift from its seating valve, allowing the contents to be discharged. Releasing the operating lever returns the check and instantly cuts off the flow of extinguishant. The operation may be repeated as often as desired (with decreasing effectiveness) until the extinguisher is empty.

Note: The extinguisher must be recharged immediately after any use.

3. SPECIFICATIONS

Model Number	R9AF
Extinguisher Capacity	9.0 litres
Mass: Extinguisher charged	12.5 kg (approx)
Diameter of body	180 mm
Height overall	592 mm
Operating Pressure	1030 kPa
Standard Test Pressure	2.5 Mpa
Periodic Test Pressure	2.0 MPa
Performance: Discharge time	XX seconds (approx)
Range	3-5 metres
Packaging:	Each extinguisher is individually packed, uncharged, complete with wall hook in a rigid cardboard carton suitable for export.

4. MATERIALS AND CONSTRUCTION

a) CYLINDER

The cylinder body is fabricated from stainless steel, with pressed stainless steel top and bottom shells, all welds being TIG. A stainless steel neck ring is TIG welded into the top end of the cylinder to accept the valve assembly.

All cylinders are pressure tested to 2.5 MPa in accordance with AS/NZS 1841 Part 1.

b) VALVE ASSEMBLY

The valve assembly is of the squeeze grip type and fitted with a 'pull out' type safety pin to prevent accidental operation. The assembly screws into the cylinder neck ring and uses a nitrile 'O' ring to affect the seal.

Valve check stem is machined from brass and is fitted with nitrile 'O' rings to affect a seal between the check stem and valve body bore and seat surfaces.

The valve spring is manufactured from stainless steel wire.

Valve body is a nickel plated machined brass forging and is supplied with a schrader air valve. Valve assembly is fitted with natural finish 304 stainless steel pressed handle and lever, secured in place by a stainless steel rivet.

- c) PRESSURE GAUGE
The gauge screws directly into the valve body and indicates the nitrogen or air pressure in the cylinder. Its colour printed face shows the normal operating pressure (1030 kPa) and the operable pressure range of the extinguisher.
- d) SCHRADER VALVE (optional)
A schrader valve is incorporated as part of the valve body and allows for direct pressurisation of the extinguisher.
- e) SIPHON TUBE ASSEMBLY
The siphon tube assembly is manufactured from plastic tubing. It is fitted with a moulded plastic strainer at the lower end. The top end is threaded to connect the siphon tube to the siphon tube adaptor nut, which retains the plunger assembly and spring in the valve assembly.
- f) LIQUID LEVEL INDICATOR
A Polyethylene filler tube is fitted into the body neck ring to indicate when the correct volume of extinguishant has been added when filling, thus preventing overfilling.
- g) SAFETY PIN
A stainless steel safety pin is fitted in the valve assembly to prevent accidental discharge of the extinguisher. This 'pull out' type pin must be removed from the extinguisher before it can be operated.
- h) LABEL
The label indicates the extinguisher contents, fire rating, and the class of fire for which it is approved. The label also features (both written and pictorial) simple operating instructions, and states the Standard and Licence number to which the extinguisher is produced.
- i) NOZZLE AND HOSE ASSEMBLY
The hose assembly is made up of braid reinforced black PVC hose to which is fitted a brass connector (for attachment to the valve) and a PA6 nozzle. It is designed to deliver a scattered stream of foam at the fire when the extinguisher is operated.
- j) WALL HOOK
The extinguisher is supplied with a hook for mounting it on the wall for ready use. The wall hook is manufactured from mild steel and is zinc plated for corrosion resistance.

5. EXTINGUISHANT

Model R9AF extinguisher is charged with 0.117 litres Presto Foam and 8.883 litres water . And it is pressurised with air or nitrogen to 1030 kPa.

6. FINISH

Extinguisher Body: Finished in red powder coat to approximate colour R13 of AS 2700.

Valve Body: Brass, Nickel plated

Handle and Lever Stianless Steel, Natural finish

7. QUALITY ASSURANCE

The company is a registered quality assured supplier operating to the ISO 9001 Quality Standard. All components are manufactured to conform to drawing tolerances and specifications that meet the specific design requirements and are subject to strict quality control at every stage of manufacture.

8. APPROVALS AND RATINGS

Approved to Australian Standard / New Zealand Standard 1841.4
Licence no. 102557

The extinguishers are endorsed by the Global-Mark for a 3A:30B fire rating.

9. INSTALLATION

For Australia, install as per Australian Standard AS 2444, Portable fire extinguishers and fire blankets - selection and location. For New Zealand, install as per to New Zealand Standard NZS 4503 - The distribution, installation and maintenance of hand operated fire fighting equipment for use in buildings.

Although components are corrosion resistant, extinguishers installed where they may be subject to aggressive environments (such as marine) shall be protected from possible deterioration as required by AS 2444 and NZS 4503.

10. SERVICING**10.1 INSPECTION and MAINTENANCE**

Periodic inspection and testing of these extinguishers should be carried out in accordance with the Australian Standard AS 1851. Maintenance of fire protection equipment. Section 15, Portable fire extinguishers, or New Zealand Standard NZS 4503 - The distribution, installation and maintenance of hand operated fire fighting equipment for use in buildings, as appropriate for the country where installed.

10.2 SAFETY PRECAUTIONS

Before attempting any repairs ensure that all propellant gas has been expelled from the extinguisher. Completely de-pressurise it by inverting the extinguisher and squeezing the operating lever.

10.3 RECHARGING INSTRUCTIONS

Recharging of these extinguishers requires no special tools. However, the repair of detail parts is impractical and all defective parts should be replaced with new parts, which are issued in kit form. To act as a guide to servicing agents, details of replacement kits are shown in the drawings at the back of this Technical Data Sheet.

The recharging of these extinguishers should be carried out as per the "after use routine" AS1851. Section 15 or NZS 4503 as applicable.

Additionally the following steps should also be followed:

Note: Before commencing, check the date of the last pressure test, which will have been recorded on the maintenance record tag.

If pressure testing is required, it must be carried out before any recharging of the extinguisher takes place.

Refer to AS 1851. Section 15 or NZS 4503 for pressure test requirements as applicable.

Proceed as follows:

- i) Observe the **Safety Precautions** as listed in 10.2, paying particular attention to ensure all propellant gas pressure has been released.
- ii) Remove hose assembly from the extinguisher valve assembly.
- iii) Remove valve/siphon tube assembly from the extinguisher body.
Unscrew slowly, if there is any residual pressure an audible sound will be noticeably heard.
The valve should not be further removed until sound ceases.
- iv) Remove anti overflow tube, empty out contents, and wash out cylinder with clean water.

- v) Thoroughly clean out internal passages of valve assembly and check for free movement of the valve check stem assembly by squeezing down on the valve operating lever and then releasing. If any form of sticking occurs strip down the valve by unscrewing the siphon tube assembly and then removing the spring and check assembly. Replace any faulty or damaged components. Before re-assembly, lightly lubricate the check stem 'O' ring with petroleum jelly. After re-assembly, again check for free movement of check stem when valve is operated.
- vi) Inspect 'O' ring on valve body and replace if damaged.
- vii) Place anti-over fill tube into neck ring of cylinder.
- viii) Fill with 0.117 litres of Presto Foam and 8.883 litres water until the liquid level reaches the bottom of the anti-overfill tube or as measured by volume or weight.
- ix) Lightly lubricate valve body 'O' ring with petroleum jelly.
- x) Screw valve/siphon tube assembly into cylinder neck, ensuring that the under face of shoulder on the valve body makes contact with the top face of the neck ring, thus retaining the sealing 'O' ring correctly. (**NOTE:** Firm hand tightening is sufficient)
- xi) Pressurise the extinguisher with air or nitrogen

SAFETY PRECAUTION

Ensure that the pressurising equipment used, fully complies with the Apparatus Safety Requirements of AS3676 Section 5.

PROCEDURE

Note: When pressurising through a schrader valve ensure that the extinguisher valve is closed and Safety pin engaged.

When pressurising through a re-charging adaptor clamp the extinguisher valve in the open position.

- a) Start by connecting the pressurising line to the schrader valve or recharge adaptor (as applicable) with the system pressure regulator set to a maximum of 150kPa above the extinguisher working pressure.
- b) Open the system pressure control valve and charge the extinguisher to its correct working pressure of 1030kPa. The pressure to be taken from the calibrated pressure line gauge, not the extinguisher gauge.

- c) Upon reaching the extinguisher working pressure, close the supply valve and if the extinguisher has been pressurised using a re-charging adaptor release the extinguisher operating lever to close the extinguisher valve and engage the safety pin.
- d) Turn off the system pressure supply and release the line pressure by opening the systems release valve. Disconnect the supply line from the extinguisher at the schrader valve or re-charging adaptor, as applicable.
- e) Where fitted remove the re-charging adaptor from the extinguisher valve.
- f) Check extinguisher gauge pointer is in the green operating range. If not replace faulty gauge, to do this the extinguisher must be depressurised first, see 10.2.
- g) Check the extinguisher for leaks as described in 10.4.

10.4 Testing for Leaks

- i) Put the fire extinguisher in the Helium leakage test station.
- ii) Start up the device to make Helium leakage test.

Note: If the device shows red light, take off the fire extinguisher and put it into the water to check the leaking position. Then rectify by replacing valve stem components, pressure gauge or 'O' rings as required. Follow instructions as per recharge 10.3.

- iii) If the device shows green light, that means there is no leakage.
- iv) Pass anti-tamper sealing tie through safety pin, around handle and lever, thread, and pull tight.
- v) Each extinguisher shall have a maintenance / service label fitted.

TROUBLE SHOOTING

TROUBLE	CAUSE	REMEDY
Leakage at valve outlet.	Foreign matter on check seat. Imperfection of seat surface. Faulty/damaged check stem	Clean surface of check. Polish seat surface. Replace check stem.
Leakage at valve/cylinder neck joint.	'O' ring defective or foreign matter on sealing surfaces.	Replace 'O' ring and clean all sealing surfaces.
Leakage at schrader valve (when fitted).	Faulty valve cores.	Replace valve core.
Leakage at pressure gauge.	Faulty gauge or thread of stem not sealed effectively.	Replace gauge if faulty. If threads not sealing remove gauge, clean threads and apply Loctite 569 and remount.

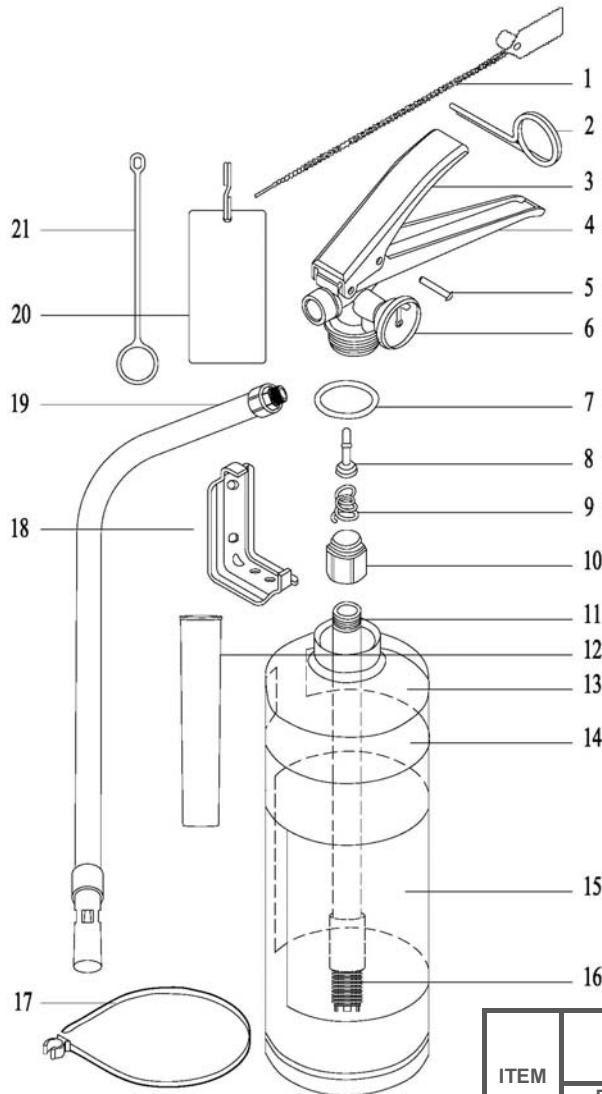

ITEM	CSP PART	DESCRIPTION	QTY
	R9AF (RH30274A)		
		9.0L FOAM FIRE EXT	1
1	RH300909	INDICATOR SEAL (WHITE)	1
2	/	SAFETY PIN (SUS304)	1
3	/	LEVER (SUS304)	1
4	/	HANDLE (SUS304)	1
5	/	RIVET (SUS304)	1
6	RH300520	PRESSURE GAUGE 1030 kPa	1
7	/	NECK SEAL O-RING	1
8	/	VALVE STEM	1
9	/	VALVE SPRING (SUS304)	1
10	/	SIPHON TUBE ADAPTOR	1
11	RH300306	SIPHON TUBE-442mm	1
12	RH300321	FILLER TUBE-107mm	1
13	RH500252	CYLINDER ASSEMBLY	1
14	/	IDENTIFICATION BAND	1
15	RH30274A-T	LABEL FOAM	1
16	/	STRAINER	1
17	RH300603	HOSE CLIP AND CABLE TIE INEGRATED	1
18	RH300728	BRACKET	1
19	RH500414A	HOSE ASSEMBLY	1
20	RH501311	HANGTAG	1
21	RH300910	SEAL (GREEN)	1